

KAN-02

1GHz, Differential Input/Output Amplifier

Functional Description

The circuit is a differential amplifier with current output and feedback. The simplified schematic is shown in Figure 1. The output impedance is set by the value of the feedback resistors (R3-R6) and the gain of the current mirrors. Amplifier gain is set by R1 and R2. All of these resistors are internal due to the high bandwidth of the amplifier.

The common mode output voltage (both outputs together) can be varied by changing the voltages on +V_{b1}, +V_{b2} and -V_b. Making all three voltages more negative (for instance, +V_b's change from +5 to +3, and -V_b changes from -5 to -7) will cause the output common mode level to become more positive. The opposite conditions will cause the output common mode level to become more negative. This can be very useful in driving differential circuits which have an elevated DC common mode input level.

By varying +V_{b1} and +V_{b2} differentially, the differential output offset can be adjusted.

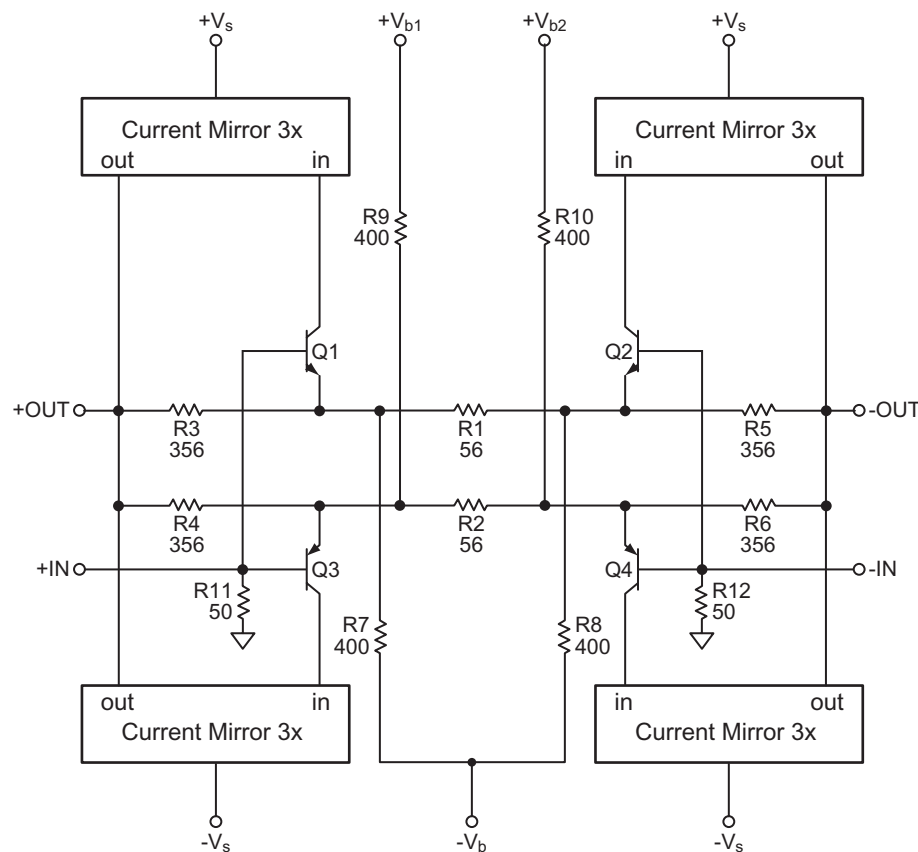

Figure 1: KH600 Simplified Schematic