

AN-6

CLC3800/CLC3801/CLC3802 Evaluation Board



Introduction

The CLC3800/CLC3801/CLC3802 evaluation board allows for quick evaluation of the following CADEKA products:

- CLC3800
- CLC3801
- CLC3802

Standard Board Configuration

The CLC3800, CLC3801, and CLC3802 must have a DC-coupled input and can drive AC- or DC-coupled outputs. The standard board configuration is DC-coupled inputs and AC-coupled outputs. Refer to the **Evaluating DC-Coupled Inputs / DC-Coupled Outputs** section for instructions on how to change to DC-coupled output configuration.

All 3 channels of the CLC3800, CLC3801, and CLC3802 can drive one (single) or two (dual) video loads. The evaluation board can be used to evaluate:

- All 3 channels driving one video load
OR
- Channels 1 and 2 driving one video load AND channel 3 driving two video loads, this configuration uses the optional OUT3_2 BNC connector

Evaluation Board Image

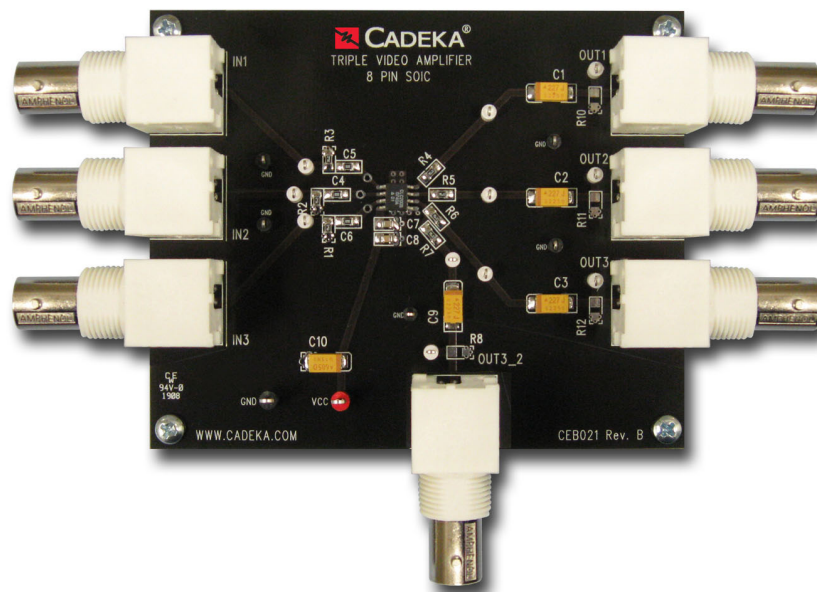

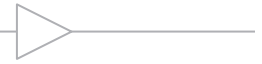

Evaluating DC-Coupled Inputs / AC-Coupled Outputs

The standard configuration of the CLC3800/CLC3801/CLC3802 evaluation board is DC-coupled inputs and AC-coupled outputs, steps 1 and 2 are already completed.

1. Short C4, C5, and C6 with 0Ω resistors
2. Insert the $220\mu\text{F}$ AC-coupling capacitors C1, C2, and C3
3. Connect the standard definition video signal from the signal source to the IN1, IN2, and IN3 BNC connectors
4. Connect OUT1, OUT2, and OUT3 to the monitor or the video measurement equipment
5. Connect the power supply to VCC
6. Connect ground to GND
7. Set the power supply to 3V (recommended power supply range is 3V to 7V)
8. Turn on the power supply

Evaluating DC-Coupled Inputs / DC-Coupled Outputs

1. Short C4, C5, and C6 with 0Ω resistors
2. Short C1, C2, and C3 with 0Ω resistors
3. Connect the standard definition video signal from the signal source to the IN1, IN2, and IN3 BNC connectors
4. Connect OUT1, OUT2, and OUT3 to the monitor or the video measurement equipment
5. Connect the power supply to VCC
6. Connect ground to GND
7. Set the power supply to 3V (recommended power supply range is 3V to 7V)
8. Turn on the power supply

Evaluating Dual Video Loads

All 3 channels of the CLC3800, CLC3801, and CLC3802 are capable of driving 2 AC- or DC-coupled video loads. The evaluation board is designed to allow channel 3 to drive 2 video loads.

1. Short C4, C5, and C6 with 0Ω resistors
2. Short C1, C2, C3, and C9 with 0Ω resistors, if evaluating DC-coupled output configuration
3. Insert the $220\mu\text{F}$ AC-coupling capacitors C1, C2, C3, and C9, if evaluating AC-coupled configuration
4. Connect the standard definition video signal from the signal source to the IN1, IN2, and IN3 BNC connectors
5. Connect OUT1, OUT2, OUT3, and OUT3_2 to the monitor or the video measurement equipment
6. Connect the power supply to VCC
7. Connect ground to GND
8. Set the power supply to 3V (recommended power supply range is 3V to 7V)
9. Turn on the power supply



Evaluation Board Schematic

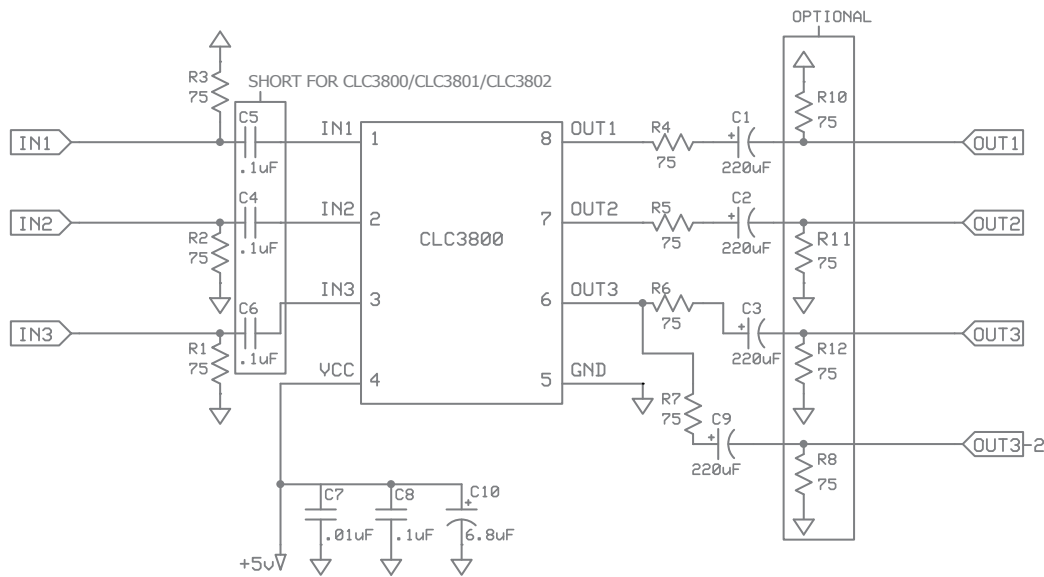

Figure 2: Evaluation Board Schematic

Component Description

The CLC3800/CLC3801/CLC3802 evaluation board uses the CEB021 PC board. This PC board is designed to be used for all 3-channel video amplifiers offered by CADEKA. Not all components are used for evaluation of the CLC3800, CLC3801, or CLC3802.

- R1, R2, R3 are 75Ω termination resistors, required for proper impedance matching to video source
- C4, C5, C6 are not used for CLC3800, CLC3801, or CLC3802 evaluation and must be shorted with 0Ω resistors
- C7, C8, C10 are bypass capacitors, the standard board is populated as shown in Figure 2. For general use:
 - C8 is optional
 - C7 can be 0.01μF or 0.1μF
 - C10 can be either 6.8μF or 1μF
- VCC is the supply voltage
 - CLC3800/CLC3801/CLC3802 operate with supply voltage from 3V to 7V
- R4, R5, R6, R7 are 75Ω series resistors, required for proper impedance matching to the video test equipment (VM700) or monitor
 - R7 is optional, use to evaluate channel 3 driving second video load
- C1, C2, C3, C9 are optional 220μF AC-coupling capacitors, short with 0Ω resistors if evaluating DC-coupled outputs
 - C9 is only used if evaluating second AC-coupled video load
- R8, R10, R11, R12 are optional 75Ω termination resistors
 - Use only if outputs are not connected and a scope is used for evaluation
- Several test-points are included to allow signal evaluation at various locations - ensure that the scope probe is properly grounded

For additional information regarding our products, please visit CADEKA at: cadeka.com

CADEKA Headquarters Loveland, Colorado

T: 970.663.5452

T: 877.663.5452 (toll free)

CADEKA, the CADEKA logo design, COMLINEAR, the COMLINEAR logo design, and ARCTIC are trademarks or registered trademarks of CADEKA Microcircuits LLC. All other brand and product names may be trademarks of their respective companies.

CADEKA reserves the right to make changes to any products and services herein at any time without notice. CADEKA does not assume any responsibility or liability arising out of the application or use of any product or service described herein, except as expressly agreed to in writing by CADEKA; nor does the purchase, lease, or use of a product or service from CADEKA convey a license under any patent rights, copyrights, trademark rights, or any other of the intellectual property rights of CADEKA or of third parties.

Copyright ©2008 by CADEKA Microcircuits LLC. All rights reserved.

Amplify the Human Experience